

## THE SHARK'S FIN MAKES THE DIFFERENCE

Perfect solution for the distribution on one level of up to 1200 pieces of baggage per hour. The m06 horizontal distributor »HSU« is used between two horizontal conveyor lines. Baggage or general cargo is distributed or merged. The belt conveyor incorporated into the horizontal distributor is swivelled using a swivel system with steel-reinforced drive belts. This maintenance-free system has been tried and tested for decades. It is also possible to use it in flight baggage systems with a container system. The belt conveyor is replaced by an appropriate conveyor element for the purposes of this.



## PRODUCT FEATURES

- Ultra-simple adjustment to required input and output positions
- Maintenance-free swivel system with tooth-belt drive
- »EIS system«: rapid assembly due to simple modular system, perfectly optimised for transportation
- Energy-efficient and economic design

## FIELDS OF USE

### Airport Solutions:

- In key locations after x-ray equipment
- Distribution and merging of conveyor lines
- Distribution and merging of bulky baggage

### Intralogistic Solutions:

- Sorting systems in the post and parcel sector

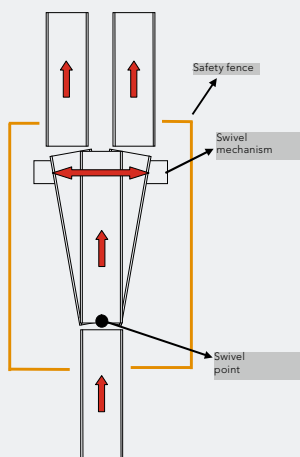

## TECHNICAL DATA

Swivel time	approx. 1 sec.
Throughput capacity	up to 1,200 units/h,
Conveyor speed	up to 2 m/s
Conveyor length	up to 5,000 mm
Belt width	up to 1,500 mm
Baggage weight	up to 75 kg

USED WORLDWIDE

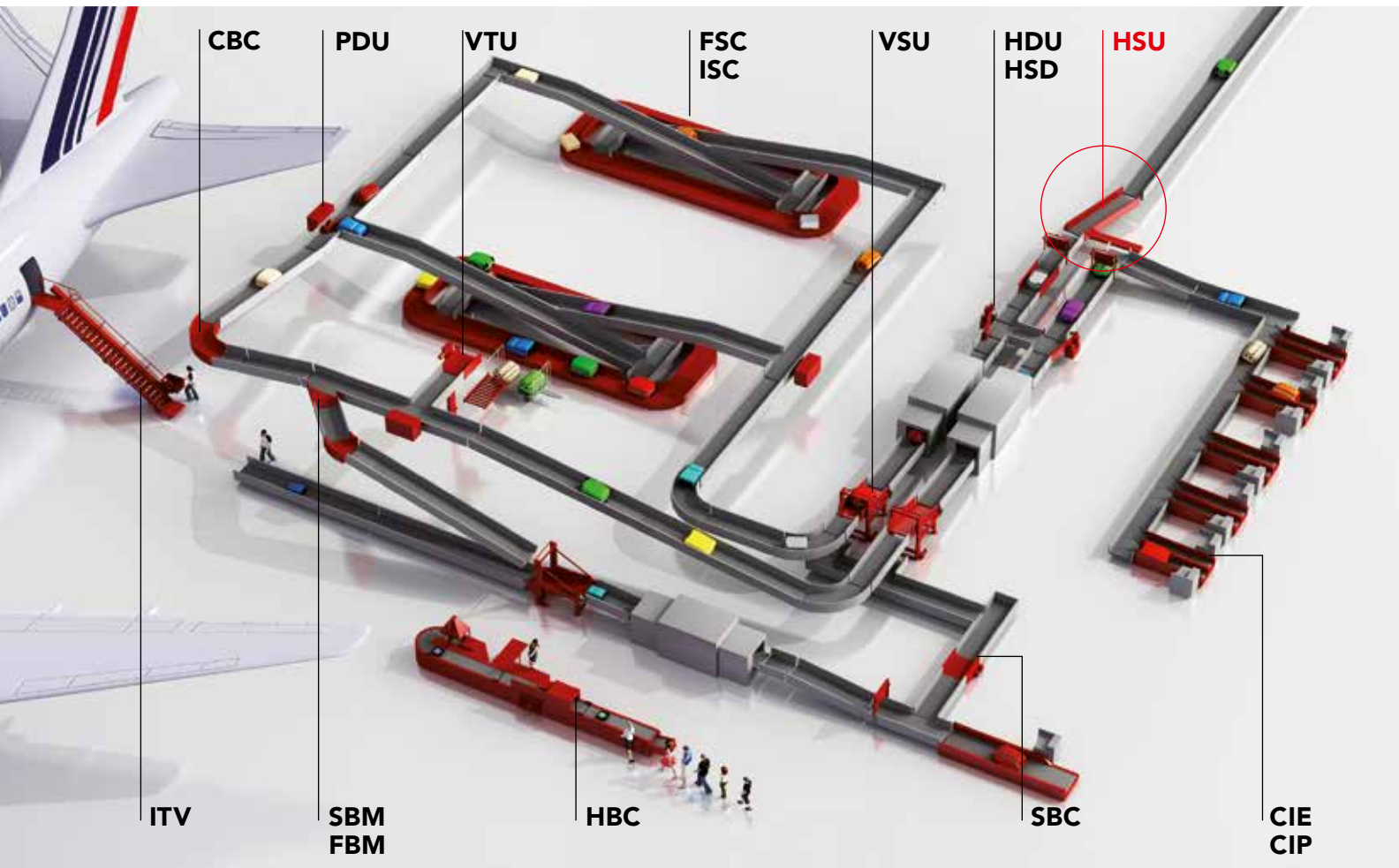

## FULL SERVICE BY MOTION06

motion06 develops, builds and installs the most intelligent conveyor systems for airports, intralogistics and industry. The foundations of our company are the highest quality standards, individual concepts and complete solutions, together with continual further development. Every one of our products stands for well thought-out, sophisticated technology, precision and intelligent simplicity. We consider project safety and speed in the implementation to be par for the course. Worldwide.