

# BESTCONNECT

## Mobile/ Reconfigurable Roller Conveyors

### Data Sheet:

#### Curved Driven Modules – BestConnect

Applicable Models: BLCM / BLCS



**BESTCONNECT**

**BESTFLEX**

**BESTREACH**

**MAXXREACH**

**SVLOADER**

## BESTCONNECT

### Product Description

The BestConnect system is designed to provide rapid assembly of conveyor solutions for changing workplaces. Systems can be easily configured and re-configured as required to suit your immediate requirements. With a simple 240v power supply and latching connections, the engineering requirement is minimal.

The equipment is highly versatile and is used for countless processes throughout multiple industries.

The BestConnect modules are also interchangeable with the other FMH catalogue products - often combining multiple Modules and products to create the perfect solution.



### Technical Data

#### Structural Data

Module Angle	30°, 45°, 90° nominal – Others available on request
Effective Width	450mm, 750mm, 900mm nominal – Others available on request
Roller Pitch	4.25°, 4.5°, 4° nominal – Others available on request
Module Height (TOR)	800mm to 1100mm adjustable height – Others available on request
Incline/ Decline	Max. 2° - Greater can be achieved on request
Side Plates	Fabricated steel (3mm)
Legs	Fabricated steel
Castors/ Feet	150mm or 200mm Brakes Castors – Foot plates available on request
Physical Connection	Roller Stop/ Connector – Splice Plates available on request

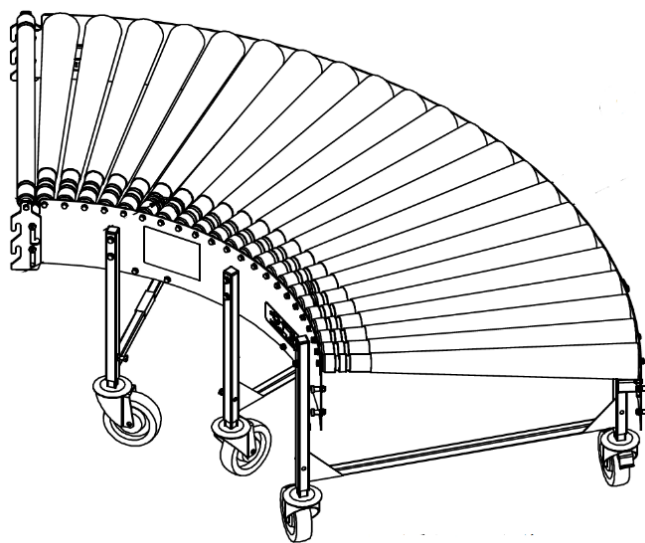

## BESTCONNECT

### Roller/ Drive Data

Roller	Ø50mm Z/P steel tube, Precision bearings, Ø12mm Z/P axles with M8 female thread with PVC Conical Taper Sleeves.
Drives	Multiple DC motors, 90W each, 20Vdc-120Vdc
Drive Method	5mm Poly-cords (85° Shore hardness) – Alternatives available on request
Torque Transmission	Roller to roller
Variable Speed	5 to 36 m/min – Controlled from the onboard speed controller
Forward/ Reverse	Both are available – Controlled from the onboard speed controller
Load Capacity	50kg / linear meter
Flow Control	Various options available on request – see Performance Options

### Electrical Data

Power Supply	230v, Single Phase, 50Hz, 16A (per Master Module)
Conveyor Connections	24Vdc – 24 Pin Harting Connection
Isolation	Localised onboard LOTO Isolator (per Master Module)
Start/ Stop Control	Push button stations at both ends
Emergency Stops	Options available on request
System Integration	Options available on request

### Efficiency Data

Noise	0 to 70dB(a)
Motor Rating	0.09kW
Max. Amperage	1.0A per motor - nominal
Sleep Modes	Options available on request
Efficiency Flow Control	Various options available on request – see Performance Options
Conveyor Speed	Potentiometer adjustable to precisely suit the operation.

### Product Principles

Powered BestConnect modules are comprised for 2 main unit variants, BestConnect Masters (BLSM) and BestConnect Secondaries (BLSS). To create a driven system, the BestConnect Master is connected to the Secondary units, via the onboard Harting plugs, allowing the power and communications to run down the whole line. These BestConnect Master/ Secondary connections are what gives the product its modular and reconfigurable qualities.

BestConnect Master units support all the power and control features needed for a BestConnect system. Secondary modules give the ability to extend that system, but are by name, reliant on the feed from the Master Module upstream.

Needing only a 16A power feed, the Master's onboard control box and speed controller can support a Maximum of 16x motors. Typically (using 6000mm long modules) that equates to 1 BestConnect Master and 3 BestConnect Secondary modules – 24m of driven conveyance. Adding more Master Modules and varying styles of Secondary Modules makes it possible to create larger and more complex systems.

For more information and a visual demonstration, please see the below video link.

<https://youtu.be/5286Ri5mNLo>

**BESTCONNECT**

**BESTFLEX**

**BESTREACH**

**MAXXREACH**

**SVLOADER**

## BESTCONNECT

### Performance Options

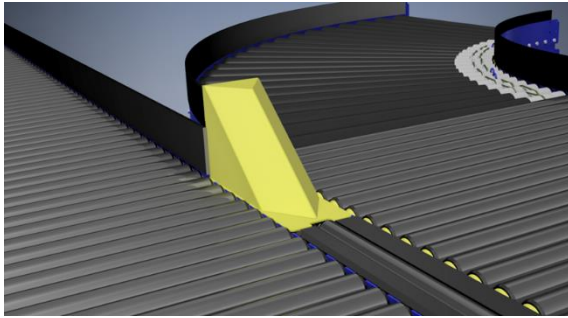

#### Side Guides

Preventing the transported goods from running off the edges of the modules. Various height options and product flow assist devices are available on request.

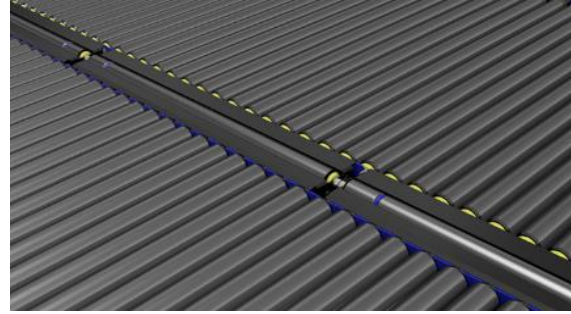

#### Manual Transition Assists

Sortation operations usually involve the lateral transition of a parcel from one module to another. FMH have developed several solutions to assist this style of operation and can offer both a skate-wheel pushover a driven roller solution.

#### Optical Electronic Flow Control

Incorporates photo electronics to provide automated flow control giving the user improved ergonomics, reduced labour cost, and improved service life. With options of using diffuse scan, retro-reflective or through-beam sensors all product shapes and materials can be detected and controlled easily.

- **Zero Pressure Accumulation** – Provides a zoned flow control only allowing each package to proceed when the downstream zone is empty. The addition of 'time out' control gives excellent power saving only driving the conveyor as required.
- **Electronic Package Stop** – The conveyor stops when sensors at the end detect a package. This stops delicate packages from being driven into a fixed end and provides power saving control.
- **Indexing** – The leading edge of a package is detected and starts the conveyor which runs until the trailing edge is detected plus a pre-set time delay. The conveyor can be utilised as an end of line storage buffer.

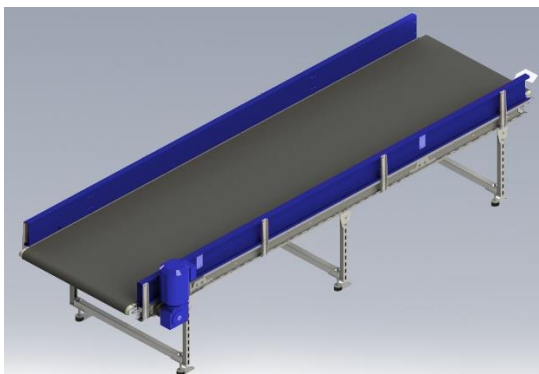

#### Integrated Equipment

The BestConnect platform lends itself incredibly well to the additions of other operational equipment. Weigh Scales, Ball Tables and Manual Sortation (OMNI) Tables can all be easily connected into a BestConnect system. Belt Conveyor options can also be integrated through our Group Partners - should the operation require that feature. For information on all integrated equipment options, please get in touch with the Sales Office.



#### Walkover Steps/ Access

To provide regular operations or emergency access over any style of BestConnect system, FMH offer a variety of Stepmover solutions that can enhance a systems efficiency. The 1200mm wide stairwell gives capacity for 2-way traffic whilst the upgraded handrail gives zero gaps or snags. All options and styles available on request.